

Säleiköt yms.

Louvre slats etc.



Alumiiniset  
rakennusjärjestelmät  
Building Systems  
in Aluminium

Säleiköt yms.

Purso Oy vastaa tämän tuotekansion detaljien toimivuudesta, mutta muista sovelluksista vain erikseen sovittaessa.  
Vastuu rakenteiden valmistuksen ja asennuksen valvonnasta ei kuulu Purso Oy:lle.

Purso Oy quarantees the function of the applications described in this catalogue.  
Other applications are quaranteed only by separate agreement.  
Purso Oy does not take responsibility for control of the installations.

Jatkuvan tuotekehityksen vuoksi  
kaikki oikeudet muutoksiin pidätetään.

## SISÄLLYS CONTENTS

NAPSU sälejärjestelmä NAPSU Louvre Systems	1
Säleikkölistat Louvre slats	2
Panelisarja Panels	3
ALLINE-sisäkatto ALLINE-ceiling	4

NAPSU sälejärjestelmä  
NAPSU Louvre System

KAMPAKIINNITYSPROFIILI 15902/K  
VARASTOVÄRI RAL 9006

MOUNTING PROFILES 15902/K  
RAL 9006

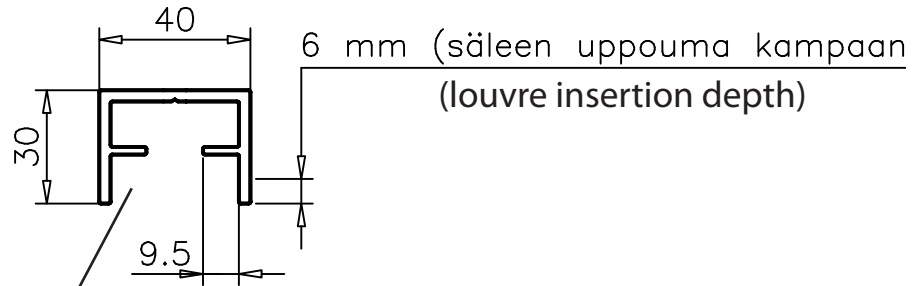
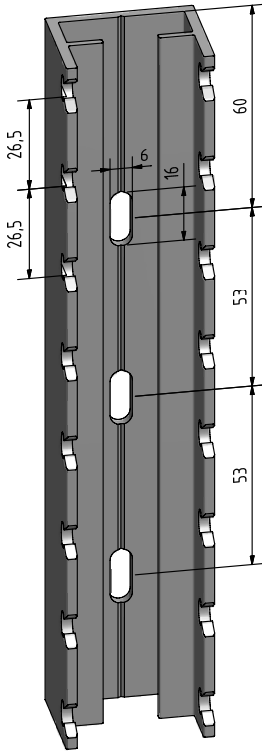

KIINNITYSKAMMASSA LAIPAT RUUVIKIINNITYSTÄ VARTEN  
MOUNTING PROFILE ENABLES SET SCREW ATTACHMENT

Kiinnityskampa tarvitsee apurungon. Max. kiinnitysväli 424 mm.

The mounting profile requires a supporting structure. The maximum mounting distance is 424 mm.

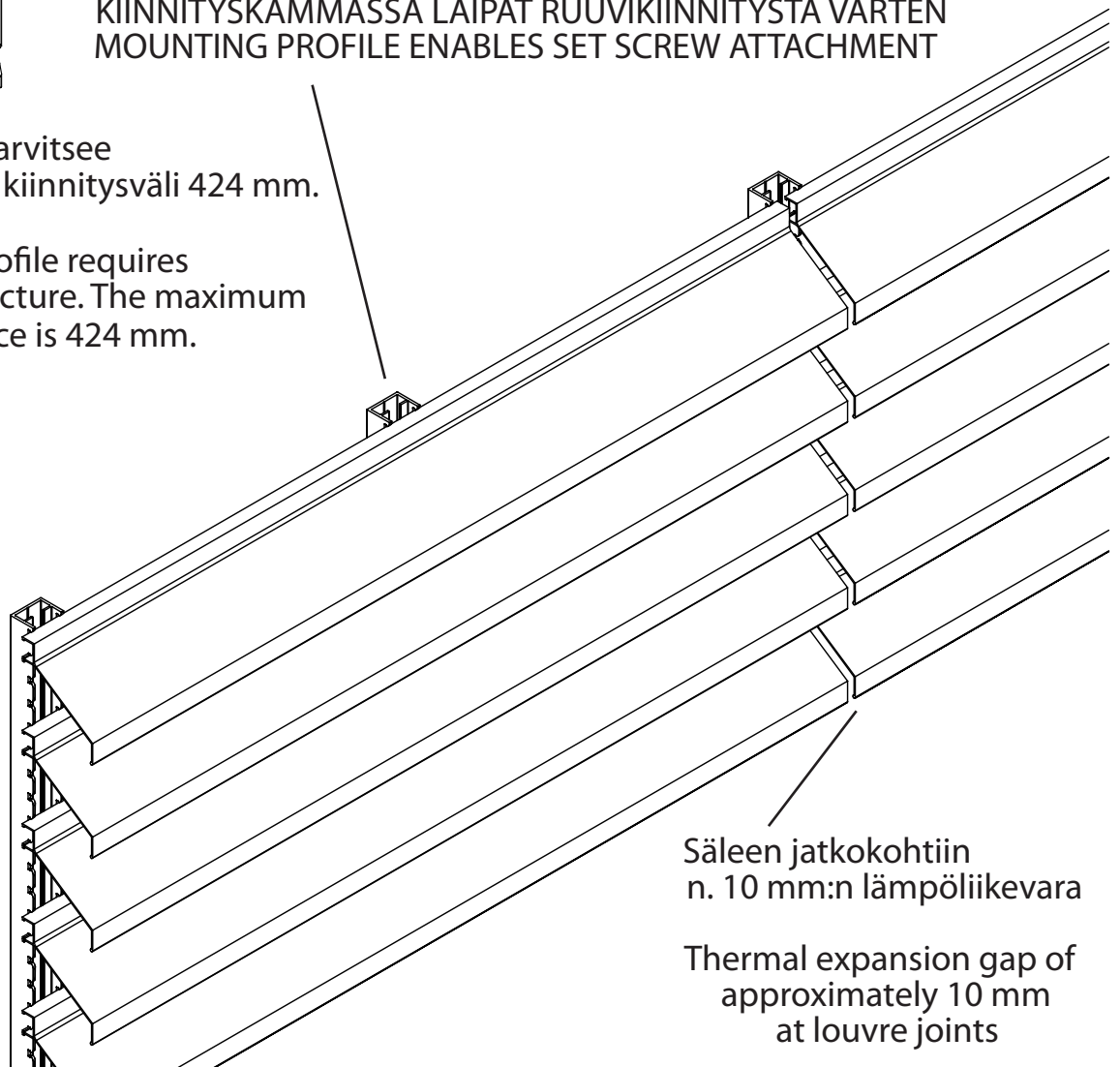

Säleen jatkokohtiin  
n. 10 mm:n lämpöliikevara

Thermal expansion gap of  
approximately 10 mm  
at louvre joints

NAPSU säleet  
NAPSU Louvre System

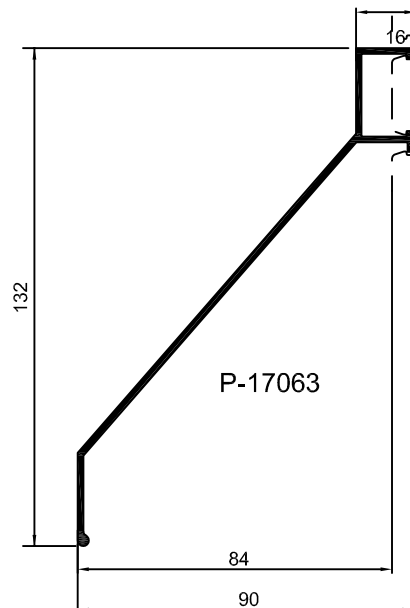
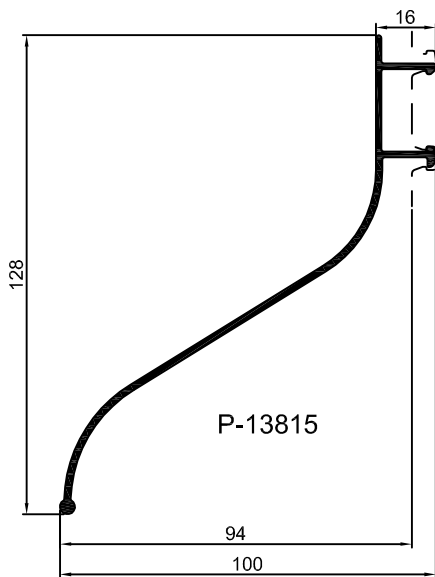
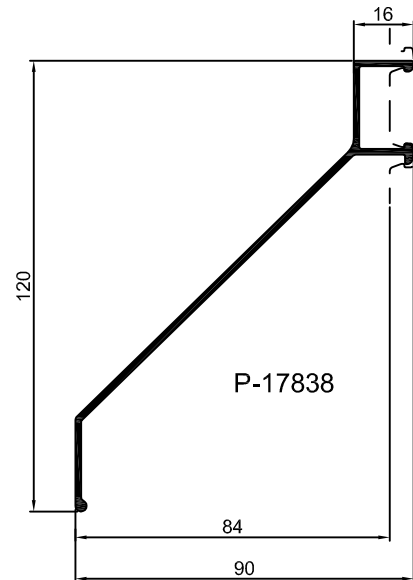
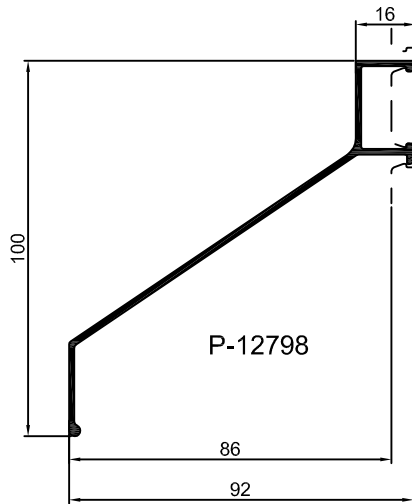
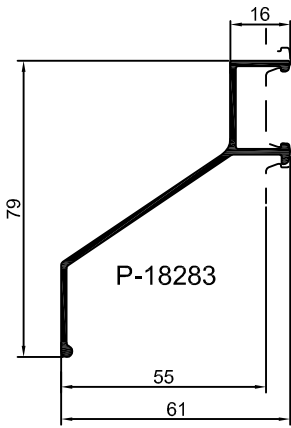
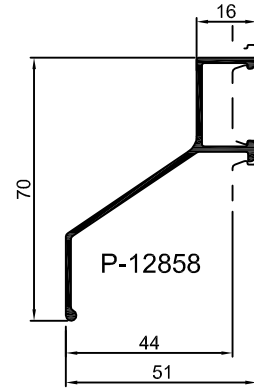
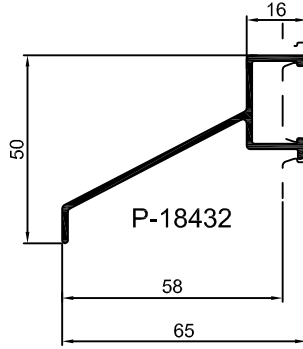
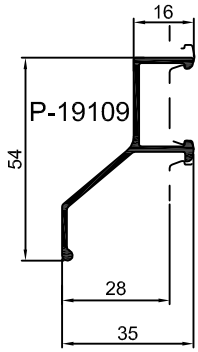

NAPSU säleät  
NAPSU Louvre System

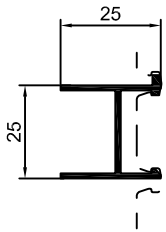
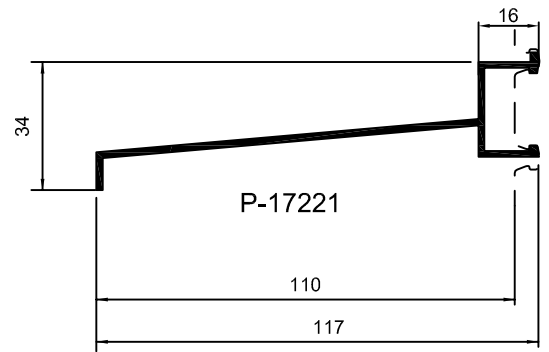
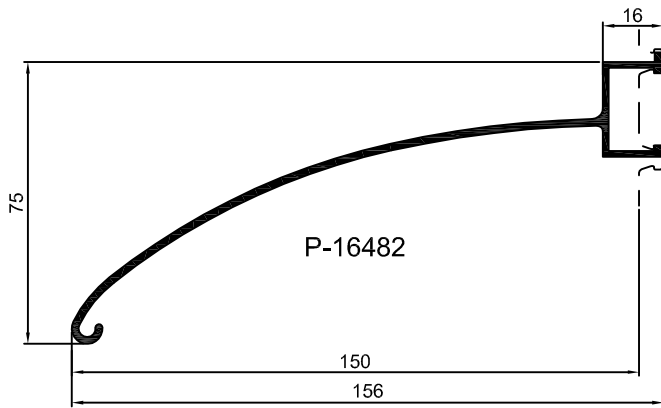

P-16878

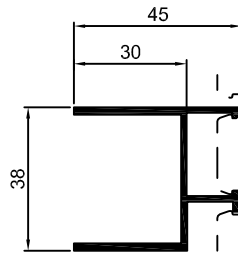

P-15843

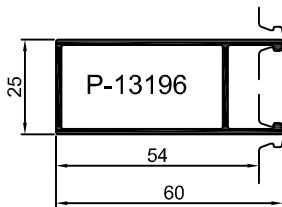
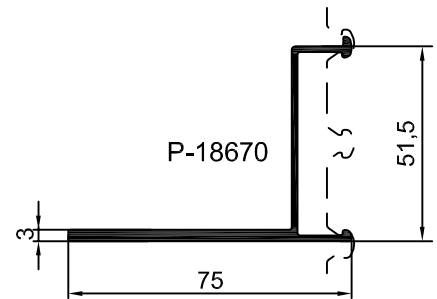

P-13196

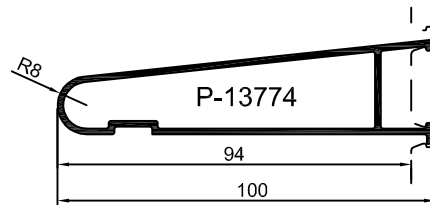

P-13774

NAPSU kiinnityspalat  
NAPSU mounting pieces

**PYSTYSÄLEIKKÖ**  
Vertical louvre systems

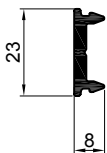
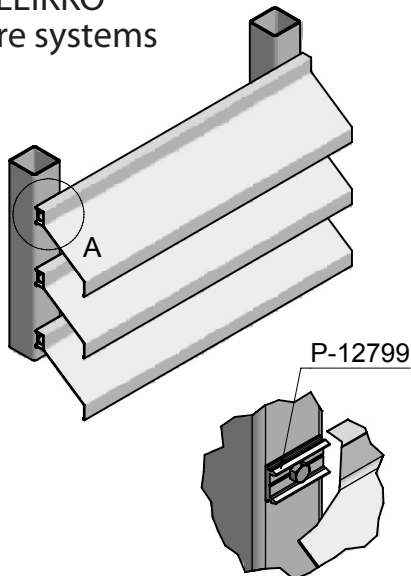

P-12799  
L=30..40 mm

**VAAKASÄLEIKKÖ**  
Horizontal louvre systems

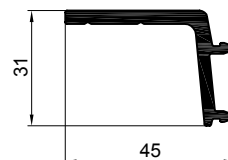
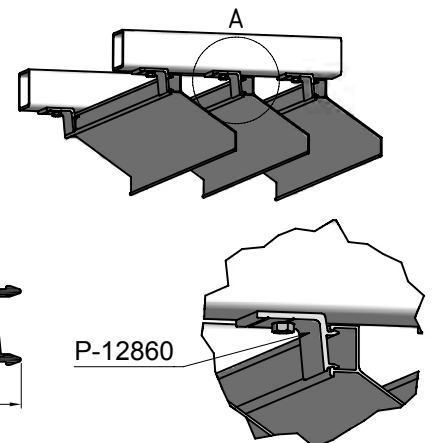

P-12860  
L=30..40 mm

NAPSU säleet  
NAPSU Louvre System

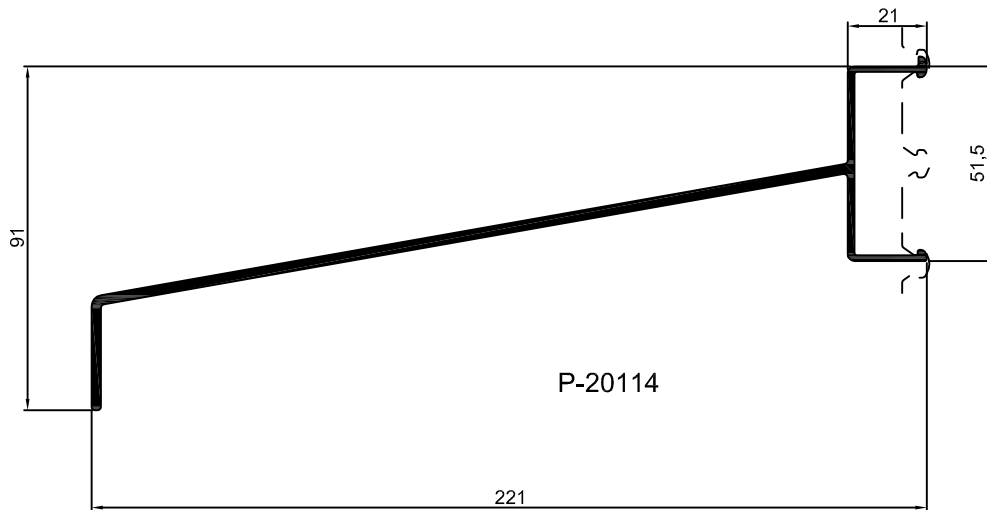
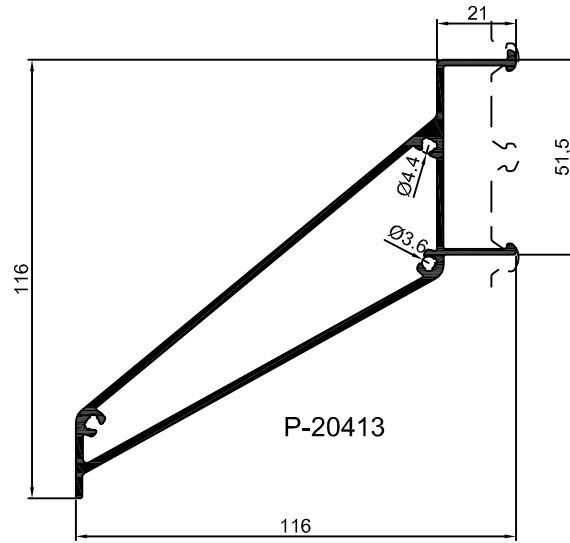

APURUNGOT JA KIINNITYSKORVAKKEET  
PROFILES AND MOUNTING BRACKETS

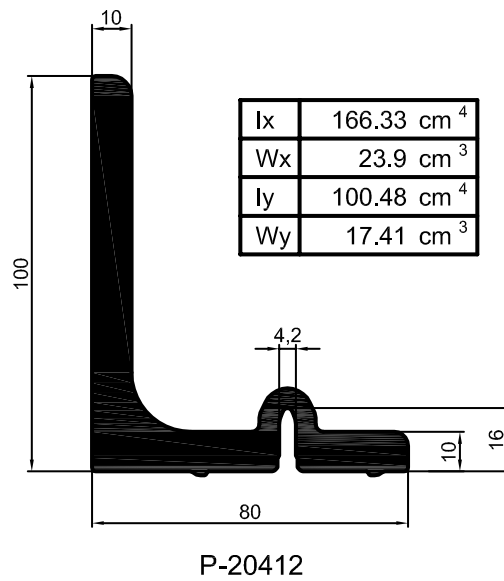

Kiinnityskorvake kiinnitetään tukevasti esimerkiksi rakennusrungosta ulkonevaan lattateräkseen  
Mounting brackets are fixed securely for example to a flat steel bar projecting out from building frame

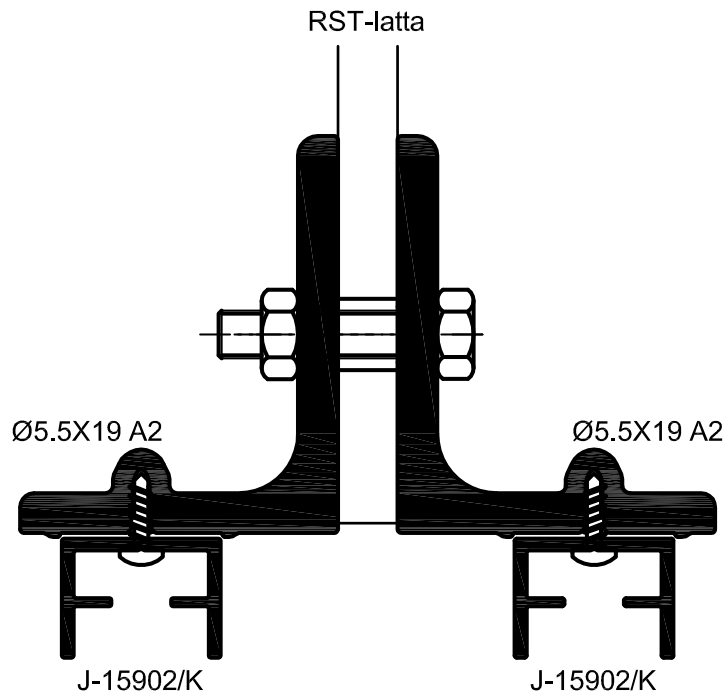



APURUNGOT JA KIINNITYSKORVAKKEET  
PROFILES AND MOUNTING BRACKETS

Runkoprofiili  
Frame profile

I <sub>x</sub>	43.12 cm <sup>4</sup>
W <sub>x</sub>	11.75 cm <sup>3</sup>
I <sub>y</sub>	20.80 cm <sup>4</sup>
W <sub>y</sub>	8.32 cm <sup>3</sup>

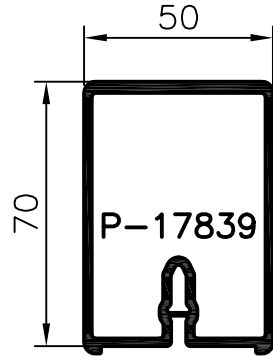

Kiinnityskorvakkeet  
Mounting brackets

17841/ (YLÄ)

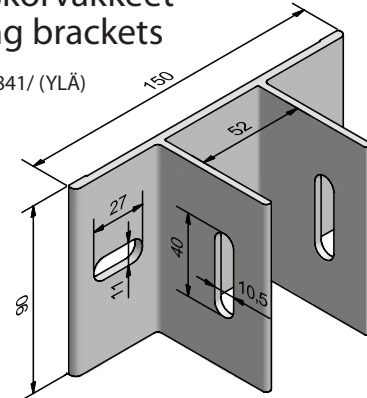

Jäykisteprofiili  
Reinforcement  
profile

I <sub>x</sub>	38.02 cm <sup>4</sup>
W <sub>x</sub>	11.55 cm <sup>3</sup>
I <sub>y</sub>	7.60 cm <sup>4</sup>
W <sub>y</sub>	3.46 cm <sup>3</sup>

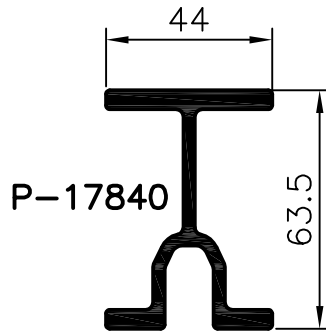

17841/ (ALA)

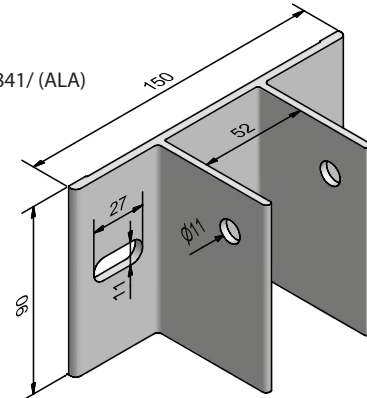

Runkoprofiili  
Frame profile

I <sub>x</sub>	86.73 cm <sup>4</sup>
W <sub>x</sub>	20.46 cm <sup>3</sup>
I <sub>y</sub>	53.35 cm <sup>4</sup>
W <sub>y</sub>	15.24 cm <sup>3</sup>

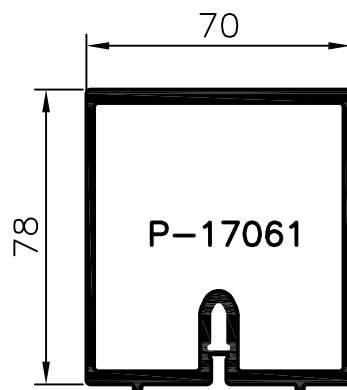

17062/ (YLÄ)

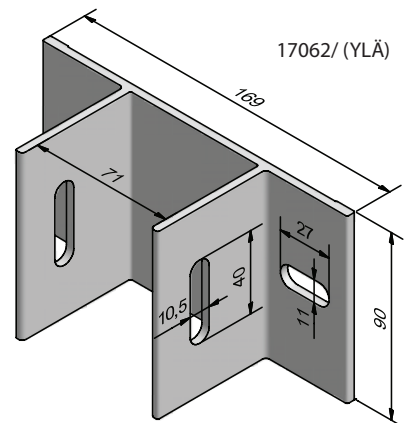

Jäykisteprofiili  
Reinforcement  
profile

I <sub>x</sub>	78.37 cm <sup>4</sup>
W <sub>x</sub>	22.16 cm <sup>3</sup>
I <sub>y</sub>	26.20 cm <sup>4</sup>
W <sub>y</sub>	8.27 cm <sup>3</sup>

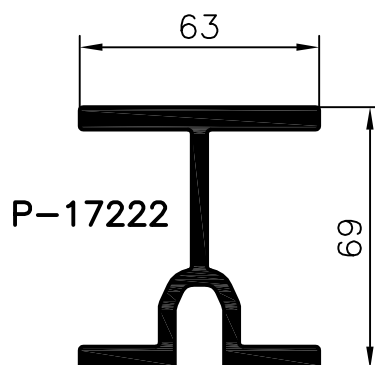

17062/ (ALA)

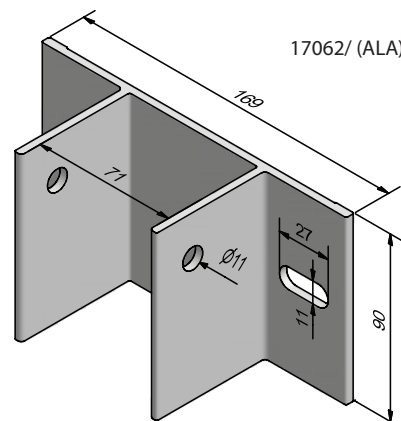

**ASENNUSJÄRJESTYS  
INSTALLATION ORDER**

1.

jäykisteprofiili  
reinforcement  
profile

kiinnityskorvake  
mounting brackets

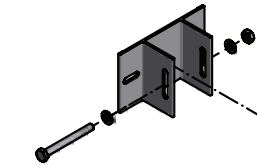

runkoprofiili  
frame profile

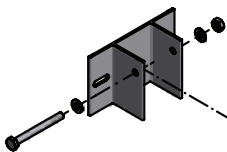

2.

kampaprofiili  
mounting profile

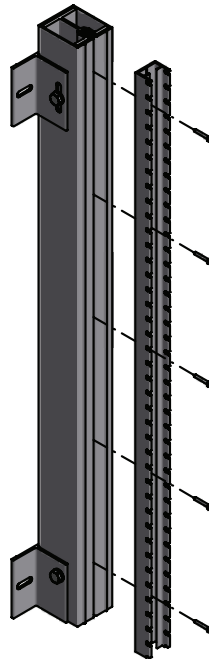

1. Kiinnityskorvakkeet kiinni ja runkoprofiili pultataan paikalleen. Jäykisteprofiili sisään tarvittaessa.

Install the mounting brackets. Bolt the frame profile into place. Insert the reinforcement profile, if necessary.

2. Kiinnityskampa ruuvataan kohdalleen.

Screw the mounting profile into place.

3.

säleiden asennus  
install the louvres

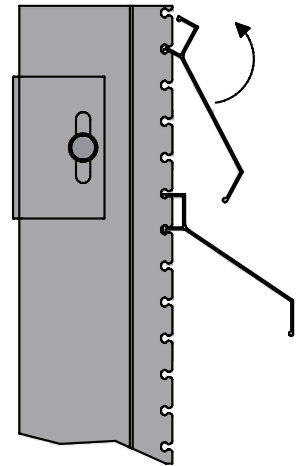

4.

valmis  
ready

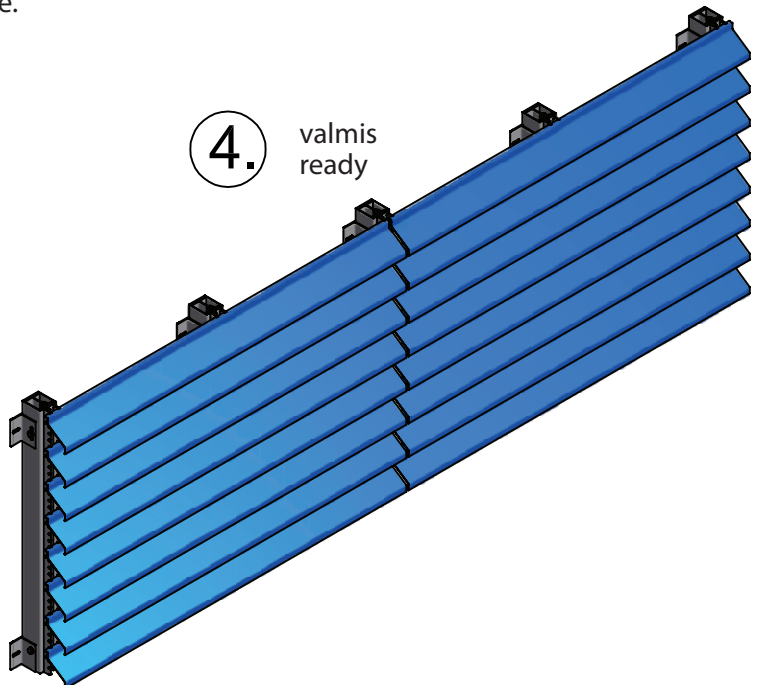

## NAPSU SÄLEET SUURIMMAT SUOSITELTAVAT JÄNNEVÄLIT RECOMMENDED MAXIMUM SPAN OF LOUVRE BLADES

Säleikkölistat kuormitettuna heikoimpaan suuntaan. Kiinnitykset tarkastettava erikseen.  
Lämpöliikkeet otettava huomioon kiinnityksissä.

Alumiinin lämpöpitenemiskerroin on  $24 \cdot 10^{-6}/^{\circ}\text{C}$ . Esim. lämpötilamuutoksen ollessa  $70^{\circ}\text{C}$ , säleen jonka pituus on 2000mm pituus muuttuu 3.4 mm

Louvre blades are loaded at the weakest orientation. Mountin must be verified separately.

Thermal movement must be taken into account when mounting.

The thermal expansion coefficient of aluminium is  $24 \cdot 10^{-6}/^{\circ}\text{C}$ . A temperature change of  $70^{\circ}\text{C}$  degrees, for instance, changes the length of a 2000 mm louvre by 3,4 mm.

Profile	kg/m	Kuormitus q Load q					
		Omapaino Dead weight		Omapaino + Tuuli 0.6 kN/m <sup>2</sup> Dead weight+ Wind 0.6 kN/m <sup>2</sup>		Omapaino + Tuuli 0.6 kN/m <sup>2</sup> + Jää 0.45 kN/m <sup>2</sup> Dead weight + Wind 0.6 kN/m <sup>2</sup> + Ice 0.45 kN/m <sup>2</sup>	
		f <sub>sall</sub> : L/500		f <sub>sall</sub> : L/300		f <sub>sall</sub> : L/100	
		L <sub>max</sub> (mm)		L <sub>max</sub> (mm)		L <sub>max</sub> (mm)	
		1-auk.	2-auk.	1-auk.	2-auk.	1-auk.	2-auk.
P-12798	0.721	2000	2000	1200	1700	1500	1500
P-12858	0.478	2000	2000	1300	1700	1600	1600
P-13196	0.637	2000	2000	2000	2000	2000	2000
P-13774	0.964	2000	2000	1900	2000	2000	2000
P-13815	0.91	2000	2000	1500	2000	1800	1800
P-15843	0.602	2000	2000	2000	2000	2000	2000
P-16482	1.056	2000	2000	1500	2000	1800	1800
P-16878	0.308	2000	2000	1600	2000	2000	2000
P-17063	0.837	2000	2000	1100	1400	1300	1300
P-17221	0.745	2000	2000	1200	1700	1500	1700
P-17838	0.797	2000	2000	1100	1500	1400	1400
P-18283	0.567	2000	2000	1300	1700	1600	1600
P-18432	0.505	2000	2000	1300	1600	1500	1500
P-18670	0.845	2000	2000	2000	2000	2000	2000
P-19109	0.383	2000	2000	1900	2000	2000	2000
P-20114	1.985	2000	2000	2000	2000	2000	2000
P-20413	1.852	2000	2000	2000	2000	2000	2000

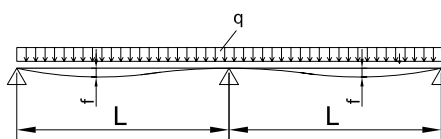
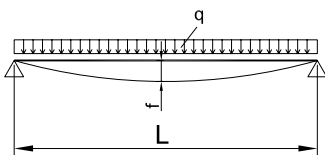

Säleikkölistojen maksimi toimituspituus 6600 mm.

The maximum delivery length four louvre blades is 6600 mm.

**P50L PEITTEIDEN LIITTÄMINEN NAPSU JÄRJESTELMÄÄN**  
**MOUNTING P50L COVER PROFILES TO NAPSU SYSTEM**

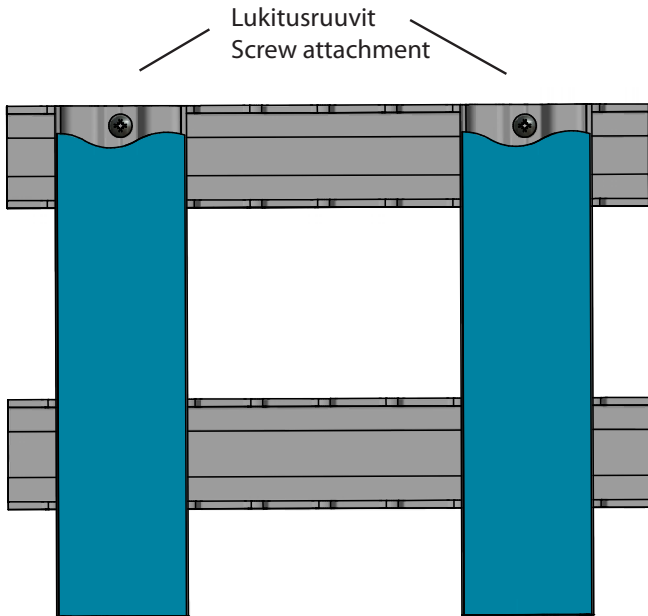

P50L sarjan peitteiden kanssa käytetään väliprofilia P-18541  
Mounting profile P-18541 needs to be used with P50L cover profiles

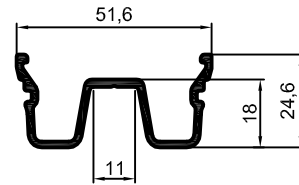

P-18541

Esimerkkejä P50L sarjan peitteistä  
Lisää peitevaihtoehtoja P50L sarjan esitteessä (tarkista peitteen yhteensopivuus väliprofilin kanssa)

Examples of P50L cover profiles  
More cover profiles can be found from the P50L catalogue (check compatibility between covers and mounting profile)

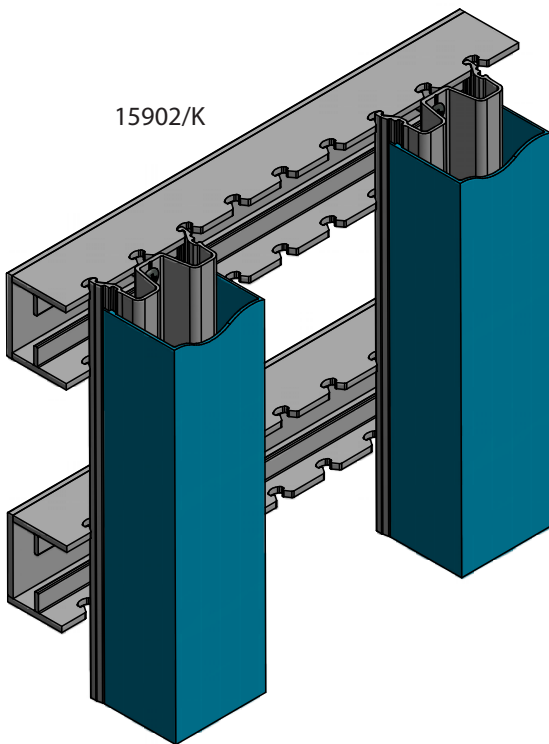

15902/K

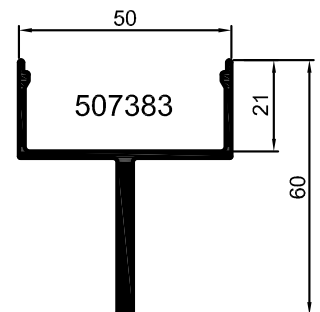
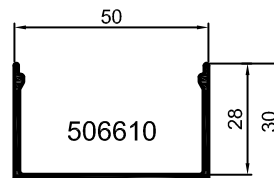
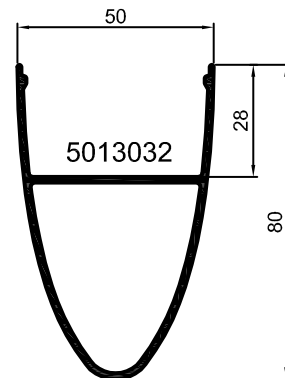

Kiinnitysprofili P-18541 voidaan käyttää pysty- ja vaakatasossa  
Mounting profile P-18541 can be used vertically and horizontal

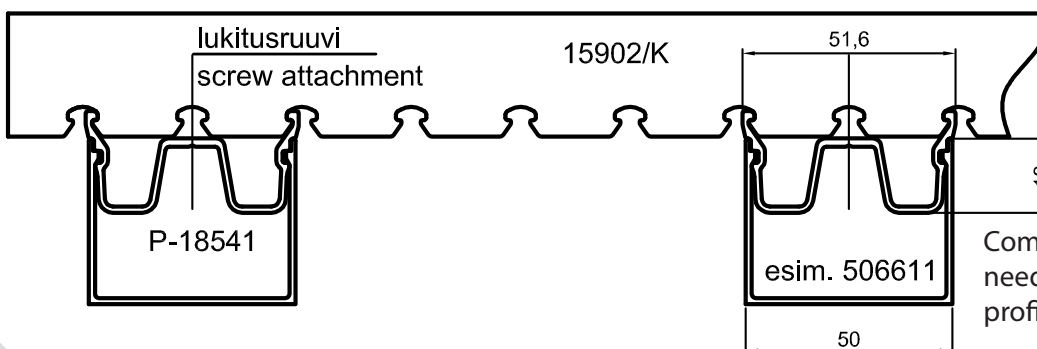

Peitteen yhteensopivuus väliprofiliiin P18541 varmistettava

Compatibility of cover profiles needs to be ensured with mounting profile P-18541

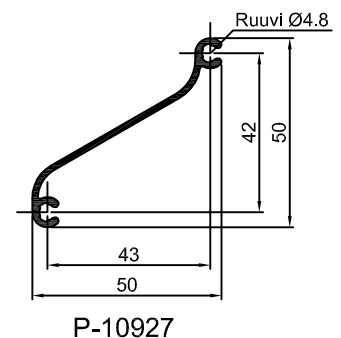
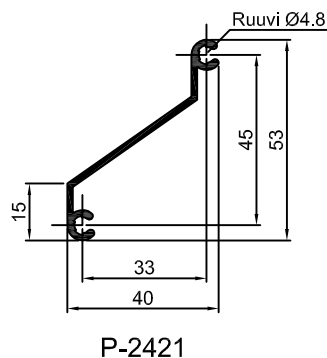
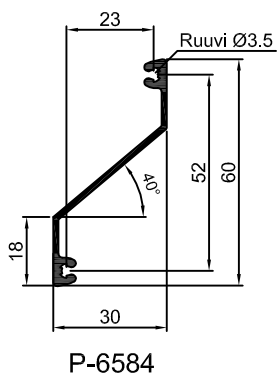
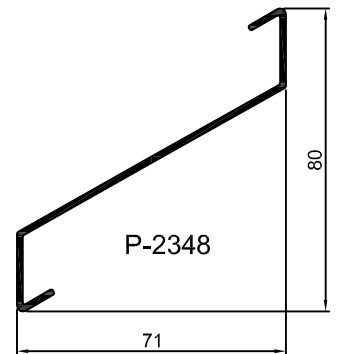
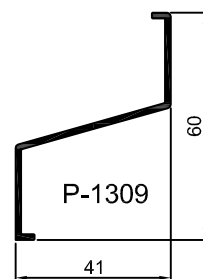
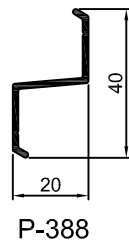
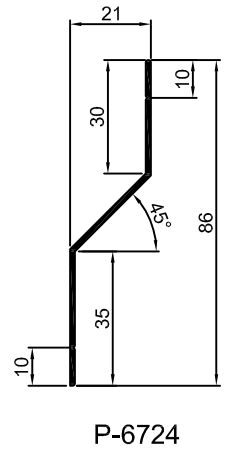
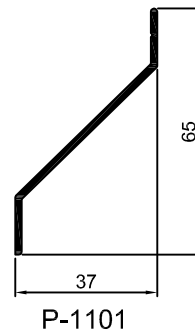
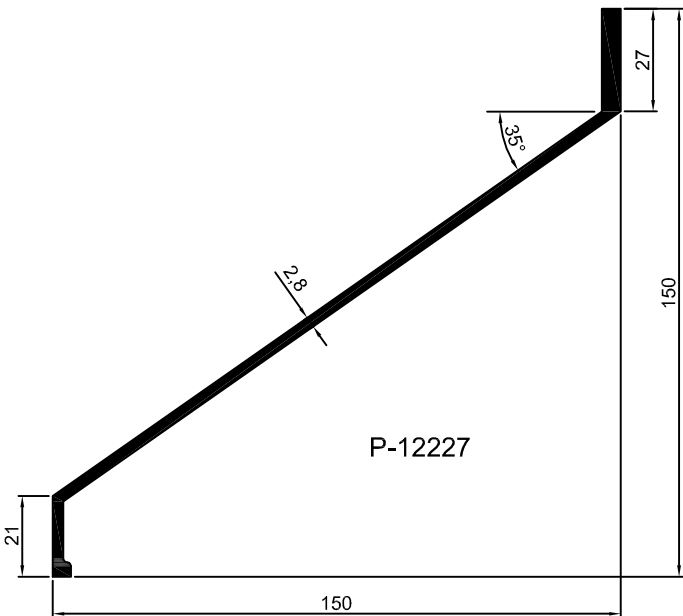
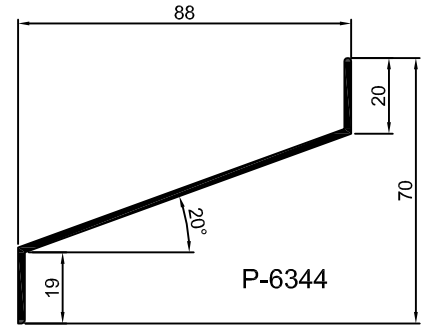
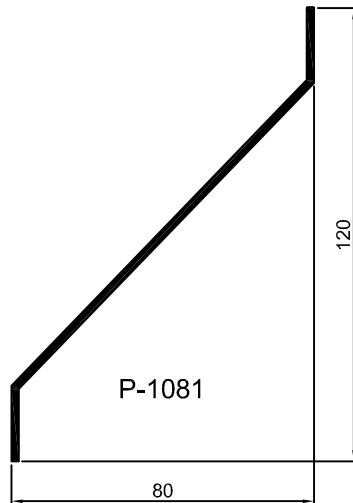
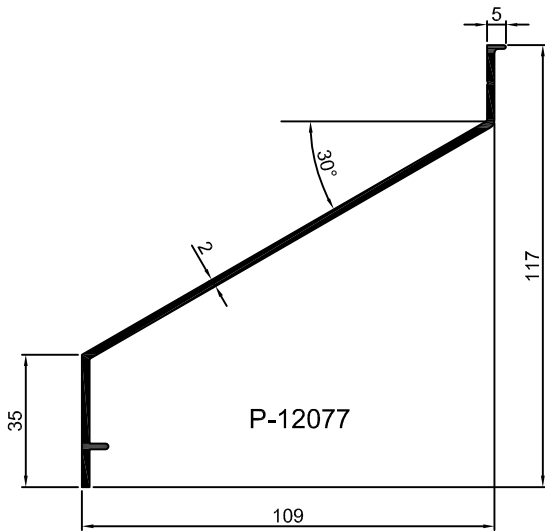

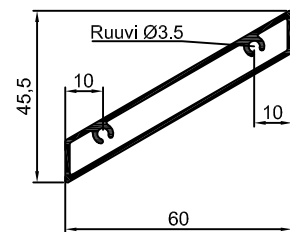
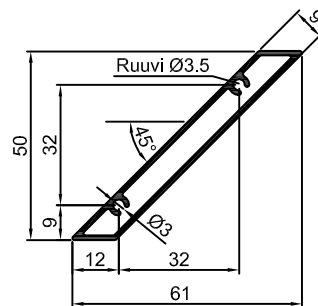
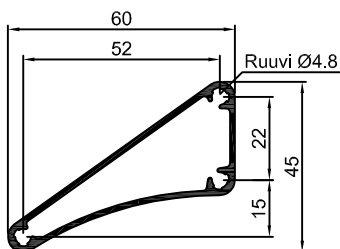
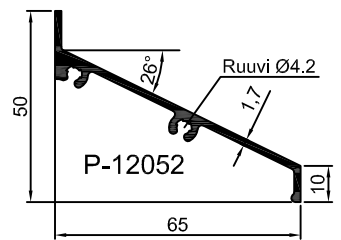
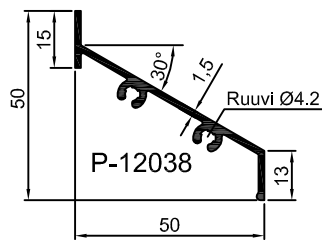
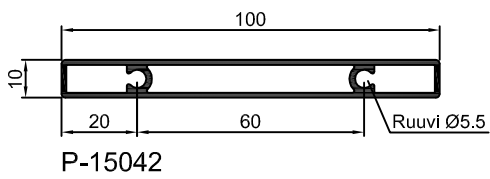
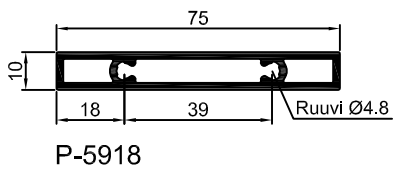
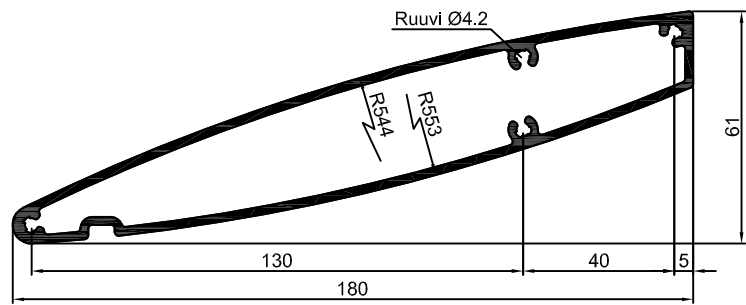
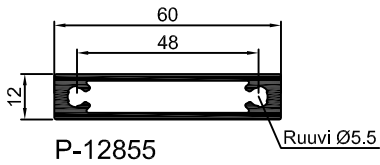
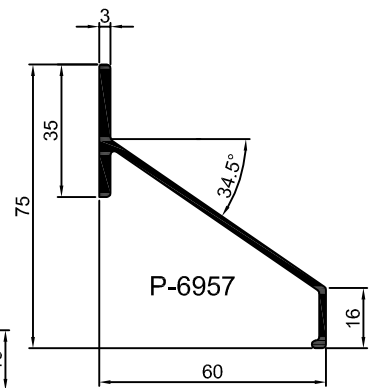
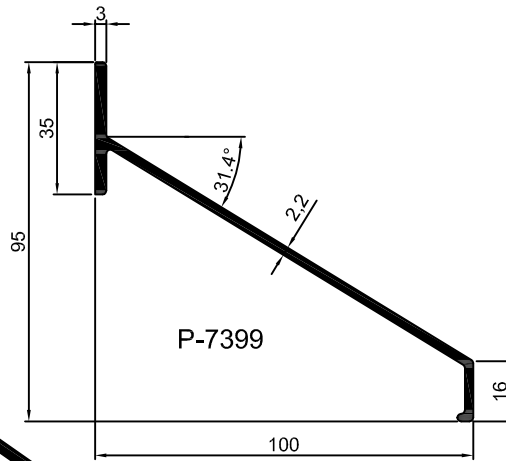
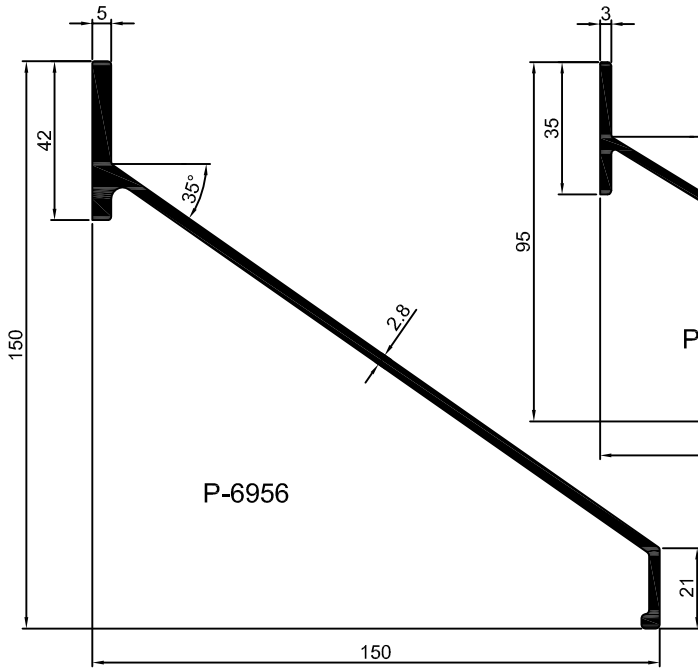

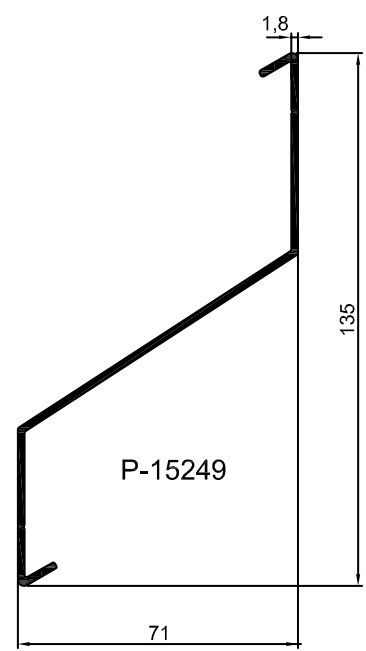
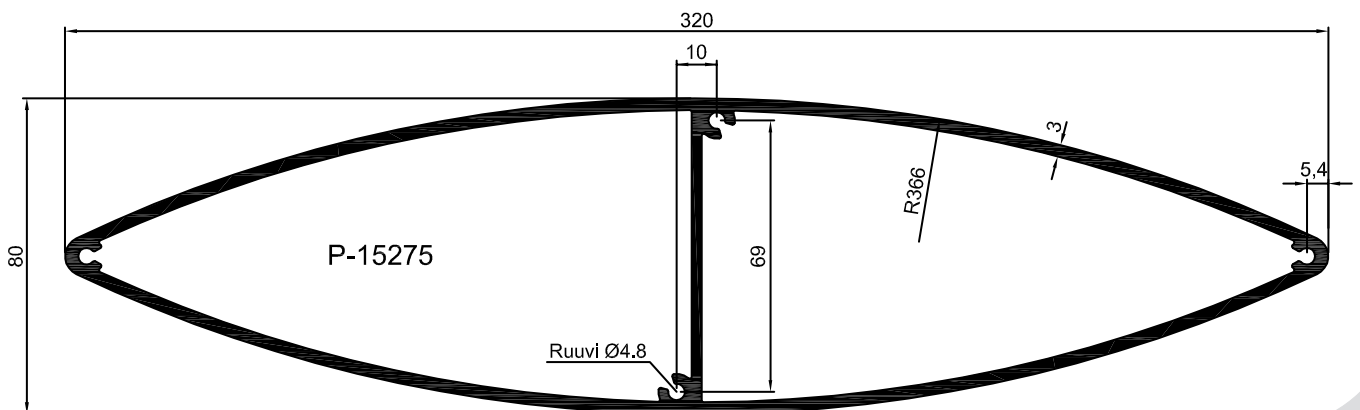
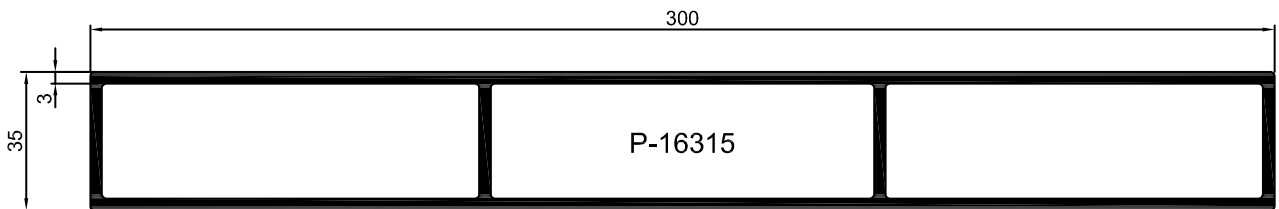
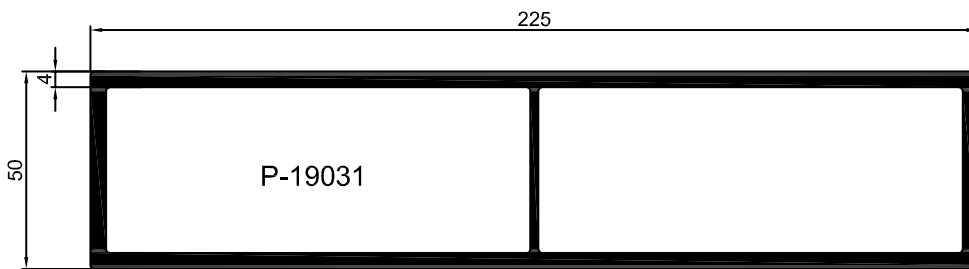
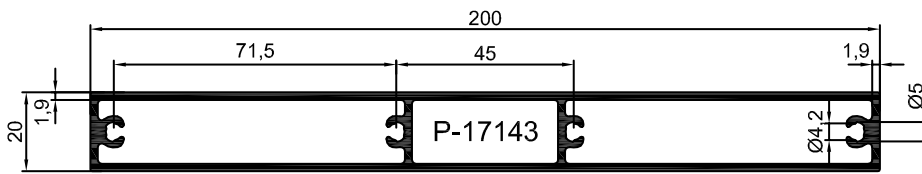
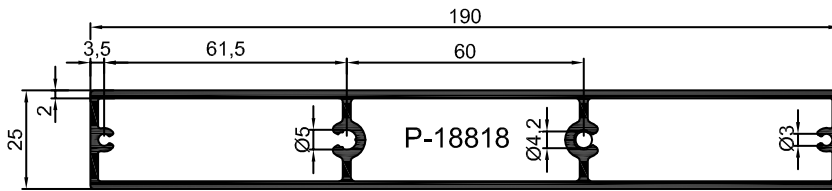
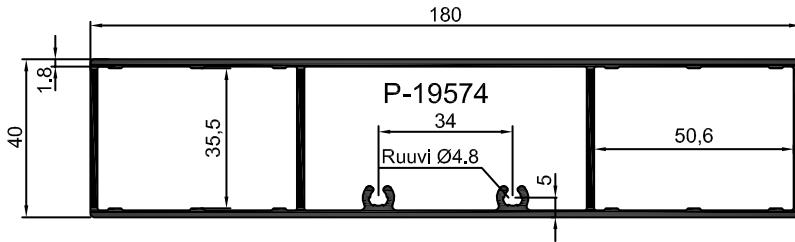
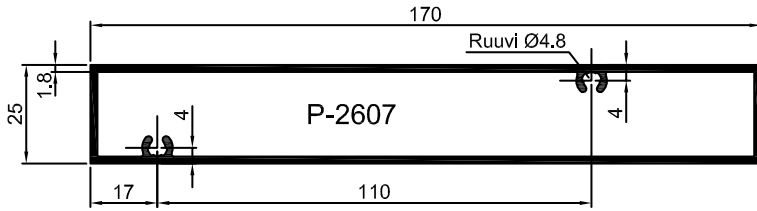
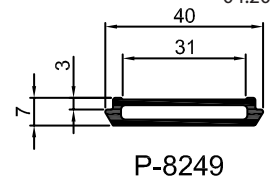
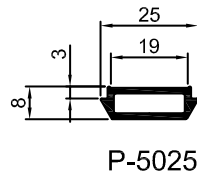
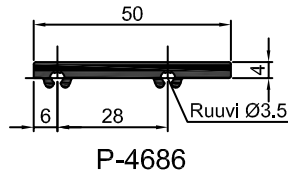
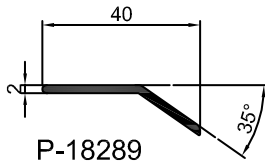

SIIPISÄLEET  
WING

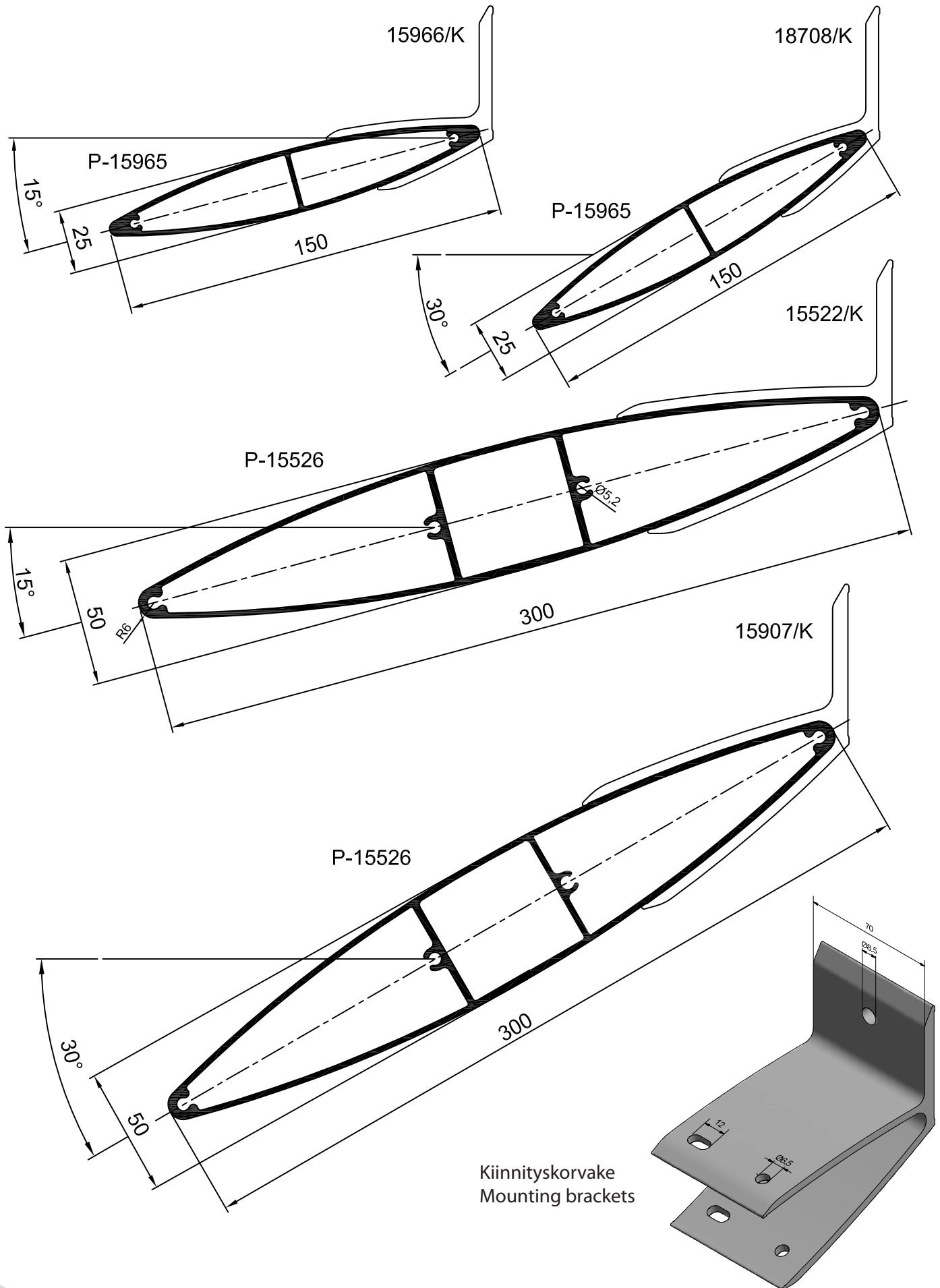



## SUURIMMAT SUOSITELTAVAT JÄNNEVÄLIT RECOMMENDED MAXIMUM SPAN OF LOUVRE BLADES

Säleikkölistat kuormitettuna heikoimpaan suuntaan. Kiinnitykset tarkastettava erikseen.

Lämpöliikkeet otettava huomioon kiinnityksissä.

Alumiinin lämpöpiteneiskerroin on  $24 \cdot 10^{-6}/^{\circ}\text{C}$ . Esim. lämpötilamuutoksen ollessa  $70^{\circ}\text{C}$ , säleen jonka pituus on 2000mm pituus muuttuu 3.4 mm

Louvre blades are loaded at the weakest orientation. Mountin must be verified separately.

Thermal movement must be taken into account when mounting.

The thermal expansion coefficient of aluminium is  $24 \cdot 10^{-6}/^{\circ}\text{C}$ . A temperature change of  $70^{\circ}\text{C}$  degrees, for instance, changes the length of a 2000 mm louvre by 3.4 mm.

		Kuormitus q Load q					
		Omapaino Dead weight		Omapaino + Tuuli 0.6 kN/m <sup>2</sup> Dead weight + Wind 0.6 kN/m <sup>2</sup>		Omapaino + Tuuli 0.6 kN/m <sup>2</sup> + Jää 0.45 kN/m <sup>2</sup> Dead weight + Wind 0.6 kN/m <sup>2</sup> + Ice 0.45 kN/m <sup>2</sup>	
		$f_{sall}: L/500$		$f_{sall}: L/300$		$f_{sall}: L/100$	
		$L_{max}$ (mm)		$L_{max}$ (mm)		$L_{max}$ (mm)	
Profile	kg/m	1-auk.	2-auk.	1-auk.	2-auk.	1-auk.	2-auk.
P-388	0.240	1800	2400	900	1200	1100	1500
P-1081	0.818	1500	2000	800	1000	900	1000
P-1101	0.365	1300	1700	600	800	700	900
P-1309	0.394	2400	3200	1200	1600	1500	1800
P-2348	0.562	2200	3000	1100	1500	1300	1700
P-2421	0.383	1500	2000	800	1000	900	1100
P-2607	1.960	3600	4900	2300	3100	2800	3800
P-4686	0.567	2000	2700	1200	1200	1000	1000
P-5025	0.230	1400	2000	800	1200	1000	1400
P-5918	0.913	1800	2400	1100	1500	1400	1900
P-6344	0.635	1900	2500	1000	1300	1200	1200
P-6584	0.389	1600	2200	800	1100	1000	1400
P-6724	0.329	1600	2200	700	1000	900	1100
P-6956	2.087	2300	3200	1400	1900	1700	1800
P-6957	0.699	2200	3000	1200	1700	1500	1600
P-7399	1.053	2100	2800	1200	1600	1400	1500
P-8249	0.362	1300	1700	800	1000	900	1300
P-10927	0.394	1400	2000	700	1000	900	1000
P-11661	0.653	2800	3800	1700	2300	2100	2600
P-12038	0.470	1400	1800	700	1000	900	1100
P-12052	0.581	1400	1800	700	1000	900	1000
P-12073	2.503	3600	4800	2400	3200	2900	4000
P-12077	0.991	2400	3200	1300	1700	1500	1500
P-12079	0.564	1600	2200	900	1200	1100	1500
P-12227	1.890	2100	2800	1200	1600	1500	1500
P-12855	0.853	2000	2700	1300	1800	1600	2200
P-15042	0.891	1800	2500	1100	1500	1300	1800
P-15151	0.575	1800	2400	1000	1400	1200	1700
P-15526	4.228	4800	6500	3200	4400	4000	5400
P-15249	0.875	3100	3300	1600	2200	2000	2200
P-15965	1.634	2900	4000	1800	2500	2300	3000
P-16315	5.805	4500	3300	3300	3300	4100	3300
P-17143	2.638	3000	3300	2000	2600	2400	3300
P-18818	2.70	3500	3300	2300	3200	2900	3300
P-19031	5.997	5700	7600	4500	6000	5700	7600
P-19574	2.651	4800	6500	3300	4500	4100	5500

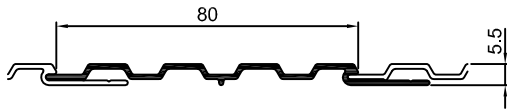

P-11666

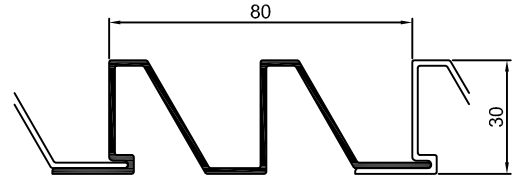

P-5461

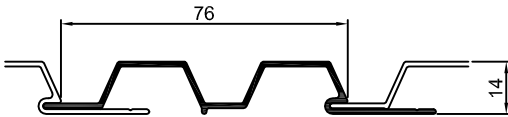

P-11665



P-1689

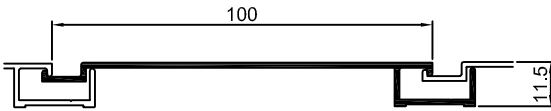

P-409

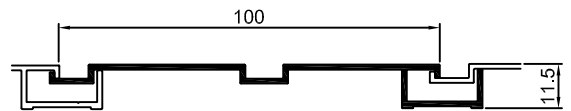

P-1872



P-12078

Väli­lista  
Intermediate strip

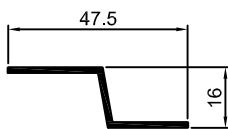

P-420

Aloit­us­lista  
Starting strip

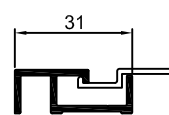

P-410

Päät­ös­lista  
Ending strip

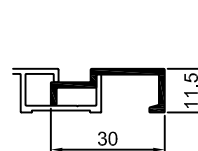

P-411

Ulkokulma  
Outer angle

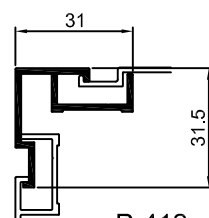

P-412

Pysty­jat­kos  
Vertical extensions

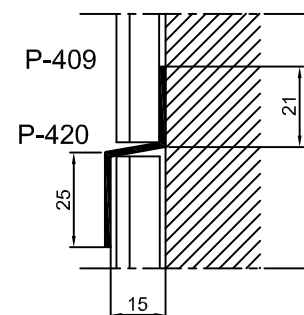

ALLINE on alumiiniprofileista koottu sisäkattojärjestelmä. ALLINESSA yhdistyvät muodon täsmällisyys, korkea laatu ja monipuoliset pintakäsittelymahdollisuudet anodisoinnista pulverimaalaukseen. ALLINE on edustava ja kovat vaatimukset täyttävä sisäkatto. Muoto ja väri säilyvät kovissakin olosuhteissa. ALLINE -sisäkattojärjestelmän etuna on joustava muotojen ja nittojen valintamahdollisuus. Järjestelmän puitteissa arkkitehti voi suunnitella täysin yksilöllisen sälemuodon kohteen omaleimaisuutta korostamaan. ALLINE-kannatuskiskot ripustetaan kannatuslankojen varaan. Kiskojen korkeussäätö on portaaton. Säleät painetaan halutuin välein kiskoihin.

Alline system gives individual look for indoor ceilings.

System can be designed and modified according to customer needs and it's easy to install.

Surface treatment: anodizing, powder coating.

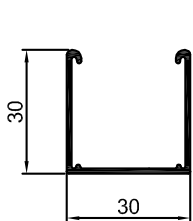
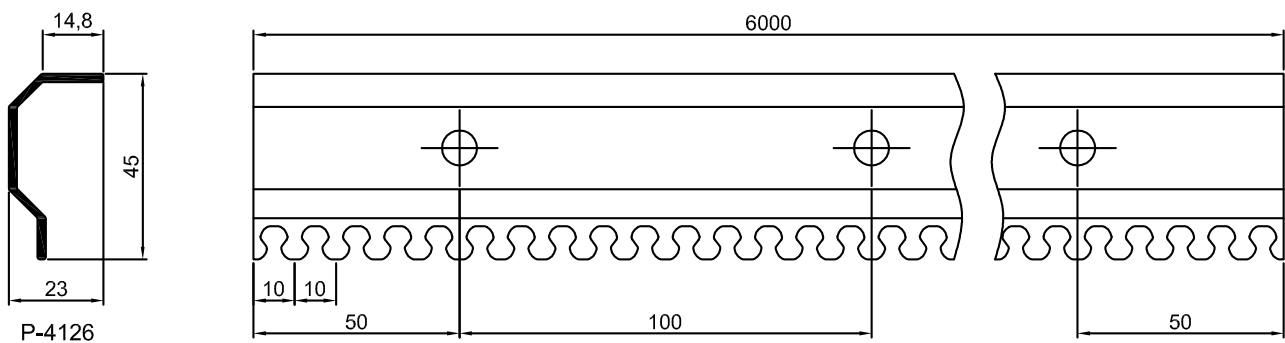

P-18384

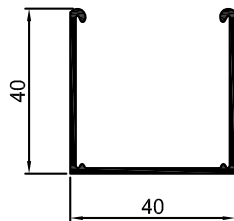

P-5283

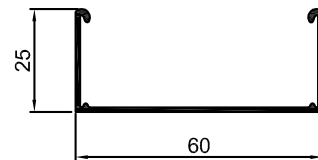

P-4102

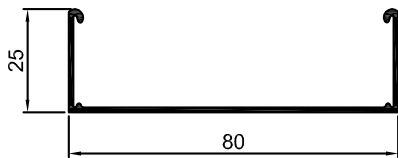

P-4103

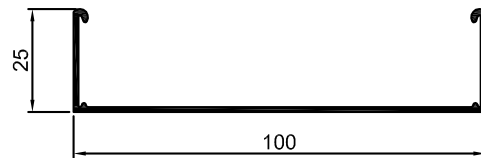

P-4104

Jatkopala 25 mm korkeille profileille  
Joint piece for 25 mm high profiles



JATKO1

Jatkopala 30 mm korkeille profileille  
Joint piece for 30 mm high profiles

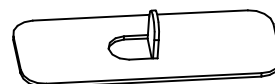

JATKO3

## Teknisiä tietoja

### Profiilit

- alumiiniseos yleensä EN-AW 6063 T5,  $R_{p0,2} \text{ min} = 130 \text{ N/mm}^2$   
 $R_m \text{ min} = 175 \text{ N/mm}^2$   
 $E = 70000 \text{ N/mm}^2$
- alumiinirakenteiden suunnittelussa on otettava huomioon lämpötilan muutoksista aiheutuvat siirtymät
- alumiinin lämpölaajenemiskerroin on  $24 \times 10^{-6}/\text{K}$
- profiilien muototoleranssit EN 755-9 tai EN 12020-2 mukaan
- seos soveltuu erinomaisesti anodisoitavaksi
- toimituspituus on normaalisti 6,6 m, muut mitat erikoistilauksesta

## Profiilien pintakäsittely

### Anodisointi

- Anodisointi on sähkökemiallinen menetelmä, jolla kasvatetaan alumiinin luonnollisen oksidikerroksen paksuutta. Anodisointi muodostaa kovan, mekaanista kulutusta kestävä pinnan, jolla on erinomainen säänkesto.

### Jauhemaalaus

- Jauhemaalauksessa profiilin pintaan ruiskutetaan pulveri, joka sulatetaan uunissa kestäväksi ja tasaiseksi pinnaksi. Ennen maalausta profileille tehdään esikäsitteily, jolla varmistetaan maalin pysyvyys. Normaalisti käytetään RAL-värikartan sävyjä, mutta muutkin sävyt ovat mahdollisia.



Valmistus, myynti ja neuvonta

Purso Oy  
Alumiinitie 1, FI-37200 Siuro, Finland  
Tel +358 (0)3 3404 111, fax +358 (0)3 3404 500  
E-mail: [purso@purso.fi](mailto:purso@purso.fi)  
[www.purso.fi](http://www.purso.fi)

Pidätämme oikeuden muutoksiin ilman erillistä ilmoitusta.

Copyright © Purso Oy 2013